

# A38E

## ELECTRIC ARTICULATED BOOM LIFT



- Popular electric articulated boom lift
- Lightweight, durable and reliable
- Smooth, easy to use controls
- Compact chassis for excellent manoeuvrability
- Suitable for indoor and outdoor use

 **snorkel**  
[www.snorkellifts.com](http://www.snorkellifts.com)

# ELECTRIC ARTICULATED BOOM LIFT

# A38E

DIMENSIONS	A38E
Max. working height	13.5m
Max. platform height (A)	11.5m
Max. working outreach	5.9m
Clearance height at max. outreach	5.4m
Platform size (E x F)	0.71m x 1.24m
Overall width (B)	1.49m
Overall length (C)	4.1m
Stowed height (D)	2.0m
Ground clearance	120mm

PERFORMANCE	
Platform capacity (SWL)	215kg
Max. drive height	11.5m
Max. wind speed	12.5m/s
Max. drive speed (stowed)	4.0km/h
Max. drive speed (elevated)	0.65km/h
Platform rotation	90° (+45°/-45°)
Turret rotation (non-continuous)	360°
Tailswing (riser boom elevated)	0m
Tailswing (riser boom stowed)	1.4m
Raise/lower time	83/68 sec
Gradeability	36%
Inside turning radius	1.12m
Outside turning radius	2.4m
Tyres	22 x 9 16 non-marking rubber
Controls	proportional controls
Drive system	direct drive DC

POWER	
Power source	8 x 6V, 220Ah batteries

WEIGHT	
Weight	3,795kg

## WORKING ENVELOPE

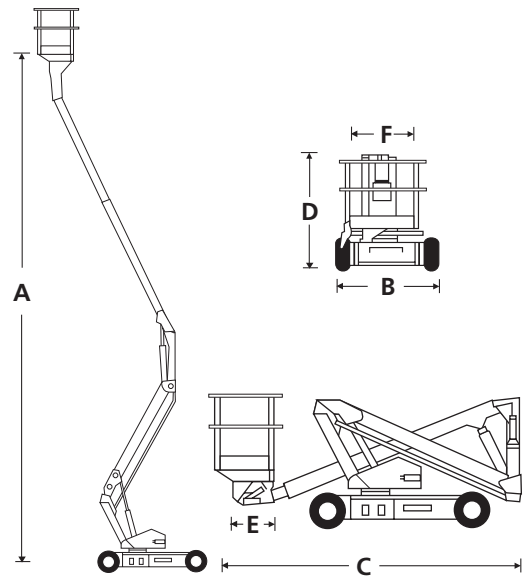
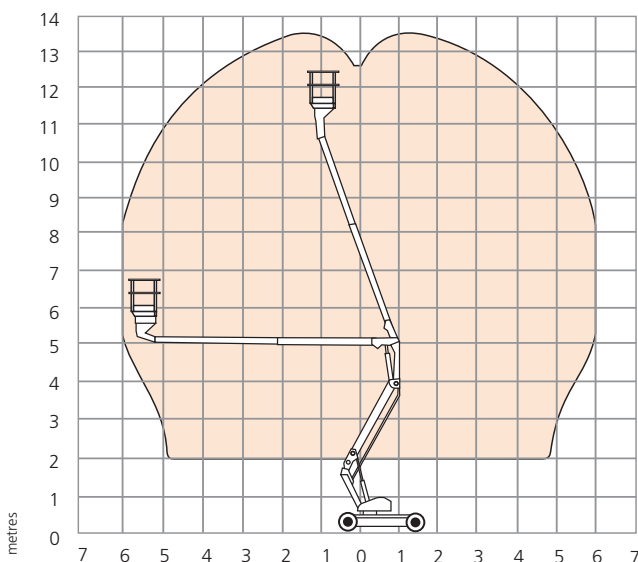

## STANDARD FEATURES

- Proportional one-handed controls
- Hydraulic platform rotation
- Minimal front boom overhang
- Ultra-tight inside turning radius
- Power line to platform
- Tilt alarm and cut-out
- 2 person + equipment capacity indoor
- 1 person + equipment capacity outdoor
- Direct DC drive parallel wired wheel motors
- Non-marking tyres
- Duplicate boom controls at ground level
- Hour meter & on-board diagnostics display
- 2 year parts & labour, 5 year structural warranty
- CE approved

## OPTIONS

- Special paint colours
- Flashing amber light
- Environmental hydraulic oil
- Upper control panel cover

**snorkel**

Vigo Centre, Birtley Road,  
Washington, Tyne & Wear,  
NE38 9DA, U.K.

t: +44 (0) 845 1550 057

e: sales@snorkellifts.com

www.snorkellifts.com