

S3006P/S3008P/S3010P

PUSH-AROUND MINI SCISSOR LIFTS



- Simple to use; easy to maintain
- Lightweight and compact
- Easily passes through a standard doorway
- No outriggers or stabilizers required
- Durable design for tough site conditions
- Platform heights of 6ft. 6in, 8ft. 2in, and 9ft. 10in.
- Proven benefits over other low level access products:
 - better job site productivity
 - safer and more convenient working conditions
 - better return on investment (ROI) for rental/hire companies

 **snorkel**
www.snorkellifts.com

PUSH-AROUND MINI SCISSOR LIFTS

S3006P 3008P/3010P

DIMENSIONS	S3006P	S3008P	S3010P
Max. working height	12 ft 6 in	14 ft 2 in	15 ft 10 in
Max. platform height (A)	6 ft 6 in	8 ft 2 in	9 ft 10 in
Platform capacity (SWL)	529 lbs	500 lbs	430 lbs
Overall width (B)	2 ft 4 in	2 ft 4 in	2 ft 4 in
Overall length (C)	3 ft 11 in	3 ft 11 in	3 ft 11 in
Stowed height (D)	5 ft 6 in	5 ft 10 in	5 ft 10 in

PERFORMANCE	S3006P	S3008P	S3010P
Max. wind speed	0 mph	0 mph	0 mph
Raise/lower time	8/14 sec	13/17 sec	19/26 sec

POWER	S3006P	S3008P	S3010P
Power source	12V DC battery		
Charger	Built in multi-voltage (90V - 240V)		

WEIGHT	S3006P	S3008P	S3010P
Weight	682 lbs	770 lbs	815 lbs

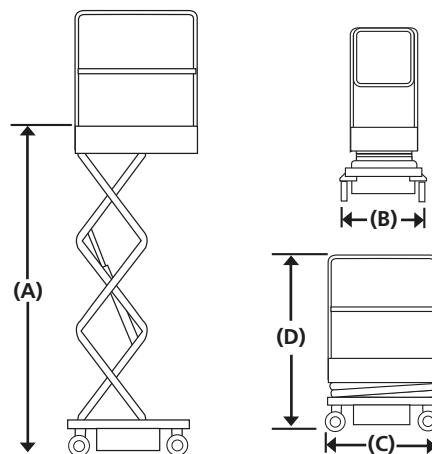

STANDARD FEATURES

- Auto brake system
- Tilt sensor
- Saloon-door style entry gates
- Integrated battery charger 90V - 240V
- Battery charge indicator
- Forklift pockets
- Emergency lowering system
- Non-marking casters
- Slide-out service trays
- 2 year parts & labor, 5 year structural warranty
- ANSI compliant

OPTIONS

- Special paint colors
- Environmental hydraulic oil
- CSA compliant

WORKING HEIGHT

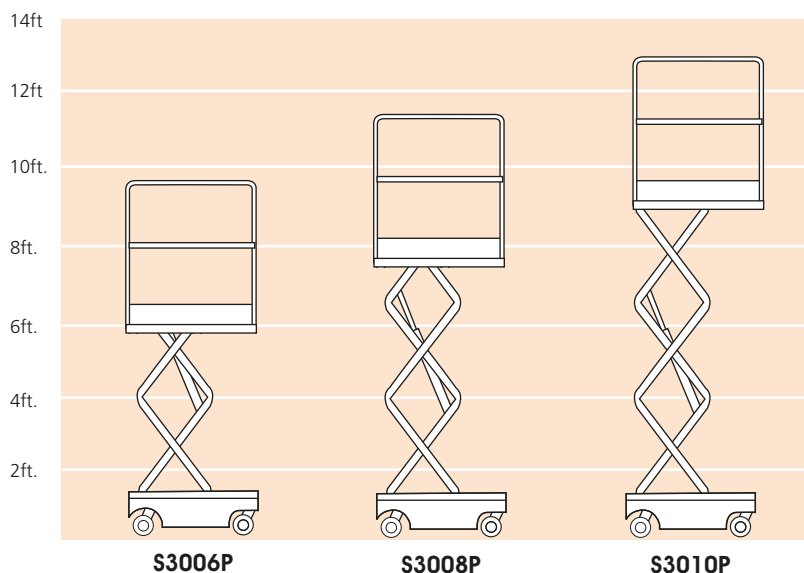

snorkel www.snorkellifts.com

P.O. Box 1160
St. Joseph, MO 64502-1160, USA
Tel: 1 (785) 989-3000
Toll-free: 1 (800) 255-0317
Fax: 1 (785) 989-3070
Email: sales.usa@snorkellifts.com