

HLS | SINGLE ACTING LOW HEIGHT CYLINDERS



Capacities from 11 to 162 tons

Stroke lengths from 0.99 to 2.36 inches

Working pressure 10000 psi

- ▶ Single acting, spring assisted return
- ▶ Compact design with optimum stroke lengths
- ▶ Nitrocarburized piston rod for corrosion resistance
- ▶ Low friction bearing surfaces
- ▶ Anti-extrusion seals for improved performance at high pressures

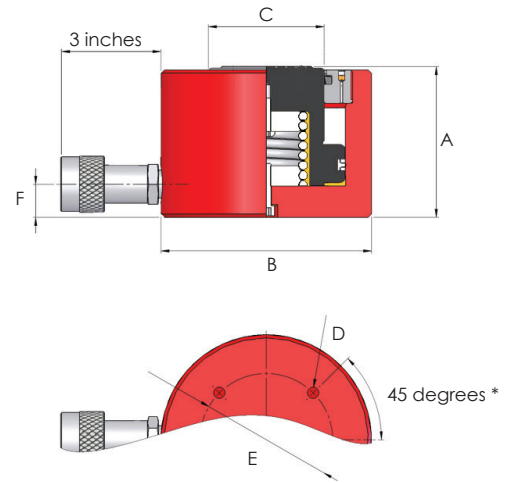

*HLS101 features 2 base mounting holes at 90° from coupler

Model number	Capacity (tons)	Stroke (in)	Oil capacity (in ³)	Cylinder eff. area (in ²)	Weight (lbs)	Dimensions (in) <i>(unless otherwise stated)</i>					
						A	B	C	D	E	F
HLS101	11	1.58	3.54	2.23	5.3	3.74	2.76	1.5	M8	1.58	0.75
HLS201	22	1.73	7.69	4.43	10.6	4.02	3.55	2.01	M8	2.36	0.75
HLS301	35	0.99	6.95	7.07	11.0	3.27	4.02	2.36	M8	3.15	0.75
HLS302	35	2.36	16.71	7.07	15.4	4.69	4.02	2.36	M8	3.15	0.75
HLS501	55	0.99	10.86	11.05	18.5	3.59	5	2.76	M8	3.15	0.79
HLS502	55	2.36	26.11	11.05	22.9	4.96	5	2.76	M8	3.15	0.79
HLS1001	120	0.99	23.42	23.78	43.7	4.26	7.01	4.49	M12	5.52	1.18
HLS1002	120	2.36	56.18	23.78	52.9	5.63	7.01	4.49	M12	5.52	1.18
HLS1501	162	0.99	31.48	31.96	81.6	5.12	8.51	4.49	M12	6.5	1.62
HLS1502	162	1.97	62.89	31.96	92.6	6.11	8.51	4.49	M12	6.5	1.62